



## Weld - On Hubs

**BTL QTL STL**

NSPT series of Weld-on Hubs can be used with assembled sprockets, flanges and fans. Working together with BTL, QTL or STL bushings, they can be installed in various transmission mechanisms.



NSPT series of Weld-on Hubs are made of high quality low carbon steel with excellent welding and mechanical capability. NSPT offers the whole series of BTL, QTL or STL bushings at the same time.

**T<sub>aper</sub>**  
**B<sub>ore</sub>**

# W/WA Weld-On Hubs

**BTL**



Type W/WA Weld-On Hubs is made of steel, drilled, tapered and taper bored to be used with relevant taper bushings. They are widely used for welding onto fan motors, pulleys, plate wheels, impellers, agitators and many other devices that must be firmly fixed to shafts.

This type of weld-on hub is rugged in constructions with advantages of easy installation and good suitability for severe operating conditions. Its structure effectively eliminates mounting difficulties. It also prevents possible loosening or wear outs on the hubs during operations.

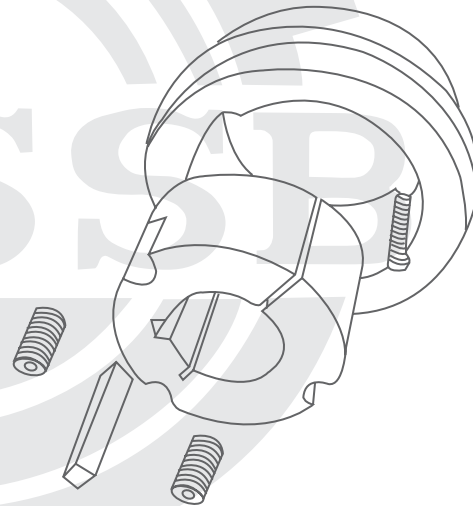
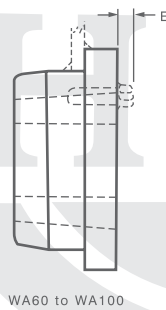
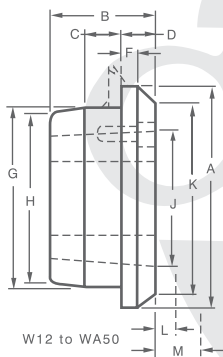

## TYPE W-WA WELD - ON HUBS

HUB NO.	BUSH NO.	BORE	A	B	C	D	E	F	G	H	J	K	L	M	WT LBS
WA 12	1215	1-2~1-1/4	27/8	1 1/2	—	5/8	—	3/8	2 1/2	—	1 7/8	2 5/8	1-3/8	1 5/8	1.2
WA 16	1615	1 1/2~1-5/8	3 1/4	1 1/2	—	5/8	—	3/8	2 7/8	—	2 1/4	3	1-3/8	1 5/8	1.3
WA 25	2517	1-2~2-1/2	4 7/8	1 3/4	—	3/4	—	3/8	4 3/8	—	3 3/8	4 5/8	1-5/8	2 1/4	3.8
WA 30	3030	1 5/16~3	5 1/2	3	3/4	3/4	—	1/2	5 1/8	4 13/16	4 1/4	5	1-13/16	2 11/16	8.6
WA 35	3535	1 3/16~3 15/16	6 3/4	3 1/2	1 1/4	1	—	5/8	6 1/4	5 15/16	5	6	2	3 3/8	15
WA 40	4040	1 7/16~4 7/16	7 3/4	4	1 1/2	1	—	5/8	7 1/4	6 7/8	5 3/4	7	2-3/8	4 1/8	29
WA 45	4545	1 15/16~4 15/16	8 3/4	4 1/2	1 3/4	1	—	5/8	8	7 5/8	6 3/8	8	2-5/8	4 3/4	42
WA 50	5050	2 7/16~5	9 1/2	5	1 3/4	1	—	5/8	8 3/4	8 3/8	7	8 3/4	2-13/16	5 1/4	57
WA 60	6050	3 7/16~6	13 1/4	5	1 3/4	1 1/4	1 7/16	—	12 1/4	11 7/8	9 1/4	—	1-5/8	4 3/8	115
WA 70	7060	3 15/16~7	14 1/2	6	2 1/4	1 1/4	1 7/16	—	13 1/2	13 1/4	10 1/4	—	1-5/8	4 3/8	158
WA 80	8065	4 7/16~8	15 1/4	6 1/2	2 1/4	1 1/4	1 7/16	—	14 1/4	14	11 1/4	—	1-5/8	4 3/8	180
WA 100	10085	7~10	19 3/4	8 1/2	3 1/2	1 1/2	1 3/4	—	18 3/4	18 1/4	14 3/4	—	2	5 3/8	340

# Taper Bore Adapters

# BTL

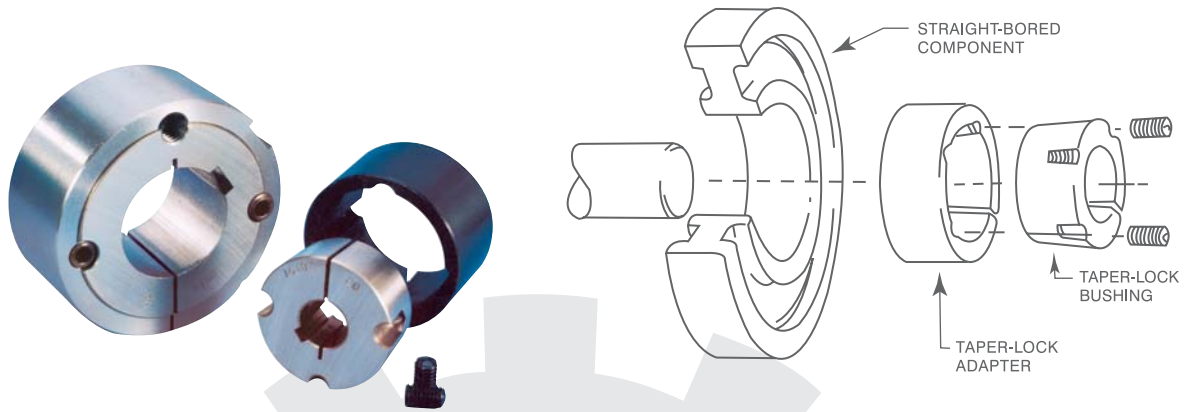

Adapters for Taper Bushing are recommended for usage where it is more convenient to use a straight bore rather than to drill and tap to accommodate bushings.

The adapter is a taper bored sleeve of grey cast iron which fits into the straight bore of a hub. The bushing simply fits inside the adapter that is tapped for the bushing screws. When tightening the locking screws, the adapter is expanded against the hub bore, pressing the bushing tightly upon the shaft.

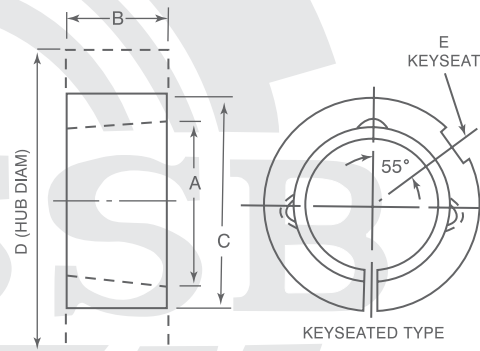

## TAPER ADAPTERS

Adapter No.	Bush No.	A	B	C	D			E Keyseat	Wt
					Class 20 Gray Iron	Class30 Gray Iron	Steel		
1215B	1215	17/8	1 1/2	23/8	35/8	33/8	3 1/4	1/4x1/8	0.7
1615B	1615	2 1/4	1 1/2	23/4	4	33/4	3 1/2	3/8x1/8	0.9
2517B	2517	33/8	13/4	4 1/8	57/8	5 1/2	5	5/8x1/8	2.2
2525B	2525	33/8	2 1/2	4 1/8	5 1/2	5 1/4	5	5/8x1/8	3.2
3030B	3030	4 1/4	3	5 1/8	73/8	67/8	6 1/4	3/4x3/16	5.8
3535B	3535	5	3 1/2	6 1/4	9 1/8	83/8	77/8	7/8x3/16	11.3
4040B	4040	5 3/4	4	7 1/4	11 1/8	10 1/8	93/8	1x3/16	17.3
4545B	4545	6 3/8	4 1/2	77/8	12	11	10 1/4	1x3/16	21.9

**T<sub>aper</sub>  
B<sub>ore</sub>** Bolt-hubs

**QTL**

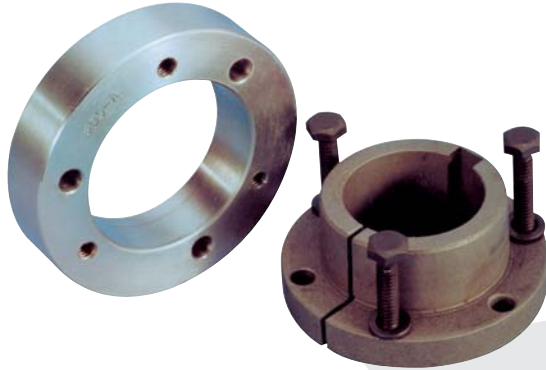

**QTL WELD-ON HUBS**

QTL weld-on hubs are suitable for many applications such as welding to plate steel wheels. Weld-on hubs are made of steel, drilled, tapered and tapered bored to be used with QTL bushing.

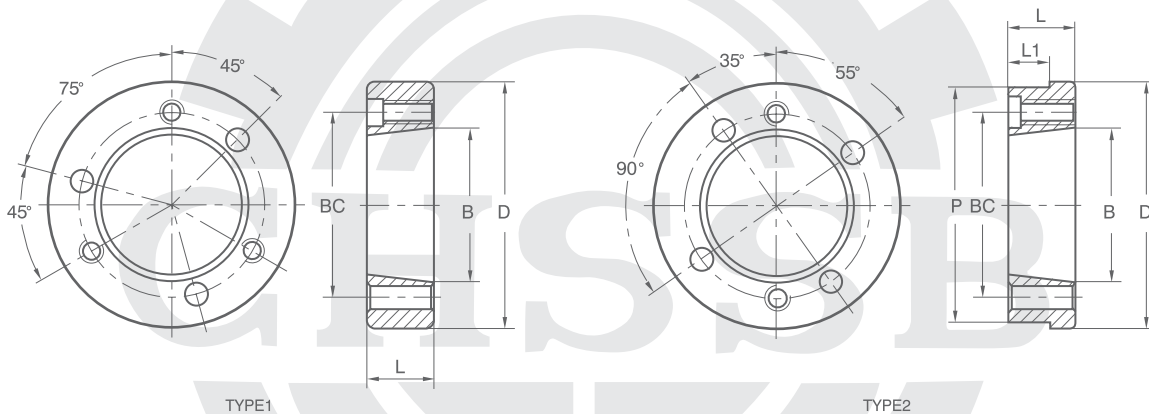

**QTL TYPE 1 AND TYPE 2 WELD-ON HUBS**

Catalog Number	Dimensions-Inches						Type Drilling BC	Torque Transmitted Bolt Stress in Pounds Per Sq.In			Weight Pounds
	D*	L	B	P+	L1	BC		6,000	9,000	12,000	
	JA	2.250	9/16	1.375	—	—		1 <sup>21</sup> / <sub>32</sub>	1	800	
SH-A	3.000	13/16	1.871	—	—	2 <sup>1</sup> / <sub>4</sub>	1	950	1,425	1,900	1.0
SDS-A	3.500	3/4	2.188	—	—	2 <sup>11</sup> / <sub>16</sub>	1	1,130	1,695	2,260	1.3
SK-A	4.375	1 <sup>1</sup> / <sub>4</sub>	2.813	—	—	3 <sup>5</sup> / <sub>16</sub>	1	2,400	3,600	4,800	3.0
SF-A	5.000	1 <sup>1</sup> / <sub>4</sub>	3.125	—	—	3 <sup>7</sup> / <sub>8</sub>	1	4,060	6,090	8,120	4.0
E-A	6.250	1 <sup>5</sup> / <sub>8</sub>	3.832	—	—	5	1	9,240	13,860	18,480	9.0
F-A	7.000	2 <sup>1</sup> / <sub>2</sub>	4.437	—	—	5 <sup>5</sup> / <sub>8</sub>	1	13,960	20,940	27,920	16
J-A	7.750	3 <sup>3</sup> / <sub>16</sub>	5.140	—	—	6 <sup>1</sup> / <sub>4</sub>	1	19,550	29,325	39,100	25
M-A	9.500	5 <sup>3</sup> / <sub>16</sub>	6.494	9.250	3 <sup>9</sup> / <sub>16</sub>	7 <sup>7</sup> / <sub>8</sub>	2	49,000	73,500	98,000	50
N-A	10.500	6 <sup>1</sup> / <sub>4</sub>	6.990	10.250	4 <sup>1</sup> / <sub>2</sub>	8 <sup>1</sup> / <sub>2</sub>	2	73,200	109,800	146,400	75

\*Tolerance of "D" - "SH" thru "J" = (+.000 -.002)

+Tolerance of "P"- "M" and "N" = (+.000-.003)

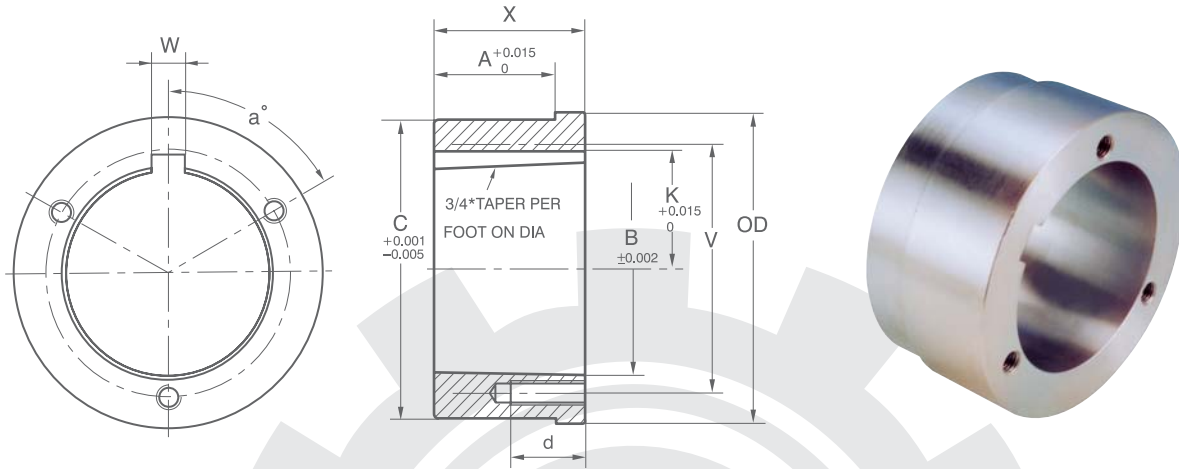

STL WELD-ON HUBS FOR STL TAPER BUSHING

Part No.	For Bushing	Dimensions									Tapped Holes		Wt Lbs.	
		OD	A	B	C	K	V	W	X	a	d	No.		Size
HG1	G	2"	.174"	1.168	1.875"	—	19/16"	—	5/8"	—	5/8"	2	1/4-20	0.4
HH1	H	2 1/2	.174	1.621	2.375	—	2	—	7/8	—	7/8	2	1/4-20	0.6
HCH1	H	2 1/2	.625	1.621	2.375	—	2	—	7/8	—	7/8	2	1/4-20	0.7
HP1	P1	3	.292	1.9375	2.875	1 3/32"	27/16	3/8"	15/16	60°	5/8	3	5/16-18	1.4
HCP1	P1	3	1.000	1.9375	2.875	13/32	27/16	3/8	15/16	60°	5/8	3	5/16-18	1.1
HP2	P2	3	1.100	1.9375	2.875	13/32	27/16	3/8	25/16	60°	5/8	3	5/16-18	2.5
HB1	B	3 7/8	.292	2.623	3.750	17/16	31/8	1/2	15/16	60°	13/16	3	5/16-18	2.3
HB2	B	4 1/2	.709	2.623	4.375	17/16	31/8	1/2	13/4	60°	13/16	3	5/16-18	4.7
HQ1	Q1	4 1/2	.709	2.875	4.375	19/16	33/8	1/2	13/4	60°	7/8	3	3/8-16	4.4
HCQ1	Q1	4 1/2	1.250	2.875	4.375	19/16	33/8	1/2	13/4	60°	7/8	3	3/8-16	4.4
HQ2	Q2	4 1/2	1.606	2.875	4.375	19/16	33/8	1/2	23/4	60°	7/8	3	3/8-16	6.9
HR1	R1	5 3/4	.709	4.000	5.625	23/16	45/8	3/4	2	60°	1 1/8	3	3/8-16	7.3
HR2	R2	5 3/4	1.606	4.000	5.625	23/16	45/8	3/4	4	60°	1 1/8	3	3/8-16	15.4
HS1	S1	6 3/4	.946	4.625	6.500	29/16	53/8	3/4	35/16	60°	15/8	3	1/2-13	17.3
HS2	S2	6 3/4	2.963	4.625	6.500	29/16	53/8	3/4	511/16	60°	15/8	3	1/2-13	30.4
HU0	U0	8 1/2	2.000	6.000	8.250	31/4	7	1 1/4	33/4	60°	2	3	5/8-11	32.0
HU1	U1	8 1/2	2.963	6.000	8.250	31/4	7	1 1/4	55/8	60°	13/4	3	5/8-11	44.6
HU2	U2	8 1/2	6.016	6.000	8.250	31/4	7	1 1/4	85/8	60°	13/4	3	5/8-11	69.0
HW1	W1	12 1/2	2.963	8.500	12.250	49/16	10	1 1/4	63/8	22.5°	13/4	4	3/4-10	130.0

PLEASE CONSULT NSPT IF MORE INFORMATION ARE NEEDED